

i2K DEFENSE PRODUCT OVERVIEW

AMERICA'S #1 MANUFACTURER OF
INFLATABLE PRODUCTS FOR DEFENSE

DECOYS & TARGETS

SHELTERS

DECONTAMINATION SHELTERS

ISOLATION CAPSULES & SUITS

TACTICAL TRAINING WALLS

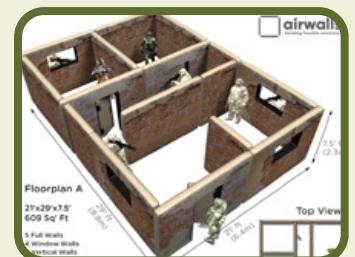

Made in
America

i2k
1993

Est. 1993

GSA Contract Holder
Contract GS03F0045U

DECOYS & TARGETS

i2k engineers have developed internal software and the use of state-of-the-art CAD technology to develop the world's most advanced inflatable military decoy targets designed to deceive the enemy as well as further advance your training exercises. Our decoys/targets satisfy the needs of the most demanding military specialists in the world. Not only do they closely resemble real aircraft, tanks and other equipment visually, but they also replicate their thermal and radar signature. From radar and other long-range scanners, these dummies are virtually indistinguishable from the real equipment. Value-added features of our inflatable dummy target for defense clients:

- In war, strategic defense means advantage over the enemy. Inflatable decoy targets help the battlefield commander implement a new proactive defense strategy.
- Defense is very costly for obvious reason. The cost of deploying inflatable decoy targets is only a fraction of the cost deploying decoys of metal or other material. i2k significantly reduces the cost to protect real and expensive military equipment.
- Unlike traditional military decoy equipment, inflatable simulation equipment is easy to install, operate, transport and store, making the associated costs significantly lower.
- Much faster setup time means rapid deployment, significant defensive effectiveness and high survivability.

DOZENS OF READY-MADE OPTIONS AVAILABLE

INFLATABLE TANKS

- T-72
- T-90
- M1 Abrams
- 2K22 Tunguska
- ZSU-23-4 Shilka
- BMP-2
- BMP-3
- ZBD-5
- MBT-3000
- Sherman
- SA-19

INFLATABLE VEHICLES

- 9K33 Osa (SA-18 Gecko)
- Pantsir-S1 (SA-22 Greyhound)
- Toyota Landcruiser w/ZU-23 Anti-aircraft Gun
- S-400 Triumph
- Scud Missile Launcher
- 2K12 Kub (SA-6 Gainful) Missile Launcher
- YJ-12 Missile Launcher
- HQ-7 Missile & Radar Vehicles
- Humvee Multipurpose Vehicles
- THAAD Surface to Air Missile System
- SA-21 Growler
- SA-21 Gravestone

INFLATABLE AIRCRAFT

- F-15 Jet
- F-16 Jet
- F-22 Jet
- F-35 Jet
- Sukhoi-30 Jet
- Mig-29 Jet
- Mirage 2000 Jet
- Blackhawk
- AH-66 Apache

INFLATABLE TANKS



BMP-3 (UAE)



M1-ABRAMS



SA-19



MBT-3000



ZBD-5



BMP-3

INFLATABLE MISSILE/RADAR DEFENSE



SA-21 GROWLER



YJ-12



HQ-7 (MISSILE & RADAR)



SA-21 PANTSIR (UAE)



SA-21 GRAVESTONE



HIMARS



SCUD MISSILE



SA-21 PANTSIR/GREYHOUND



PATRIOT MISSILE DEFENSE

AIRCRAFT



F-22



BLACKHAWK



F-16



SUKHOI-30



F-22



F-15

RAPID RESPONSE INFLATABLE SHELTERS

Shelters are your most basic needs, but your biggest logistical headache. Set up highly durable structures that can withstand any terrain and climate in minutes, and dramatically reduce your transportation costs.



Manufacturing methods: Inflatable Shelters are manufactured with high-frequency (RF) welded tubes from high-tensile strength PVC. Tubes are all independent so that if a tube were to get a hole or tear, the entire shelter won't go down like inflatable shelters from other companies. The entire top and bottom floor are also RF welded to keep water out which guarantees total impermeability.

STANDARD DIMENSIONS

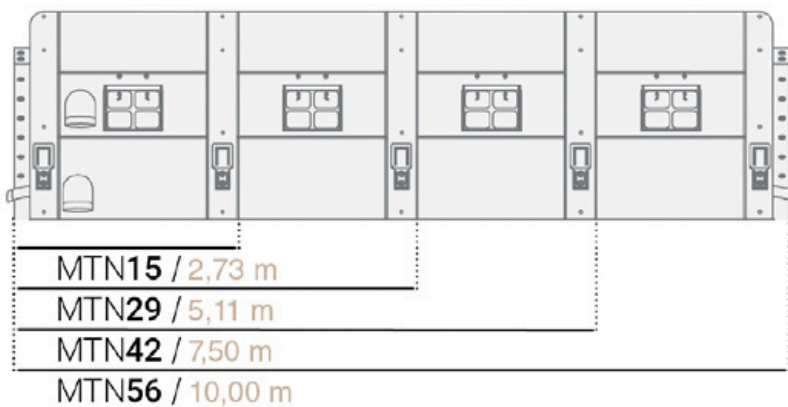
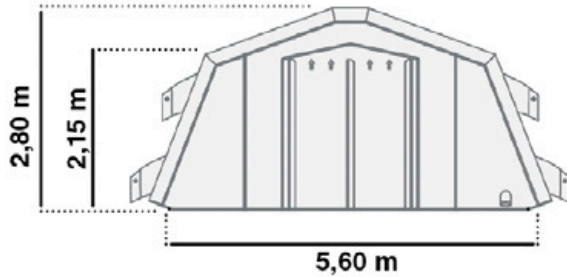

WEIGHT & VOLUME OF TRANSPORT

MTN15	MTN29	MTN42	MTN56
1,3 m ³ 112 kg	1,5 m ³ 167 kg	1,7 m ³ 235 kg	1,9 m ³ 276 kg



TIME AND PERSON NEEDED TO INSTALL

SIZE (M2)	Nº MODULES	WIDTH x HIGH x LENGTH (M)	INFLATION TIME
15	1	5.6 x 2.8 x 2.73	4 Minutes
29	2	5.6 x 2.8 x 5.11	6 Minutes
42	3	5.6 x 2.8 x 7.50	8 Minutes
56	4	5.6 x 2.8 x 10.00	10 Minutes

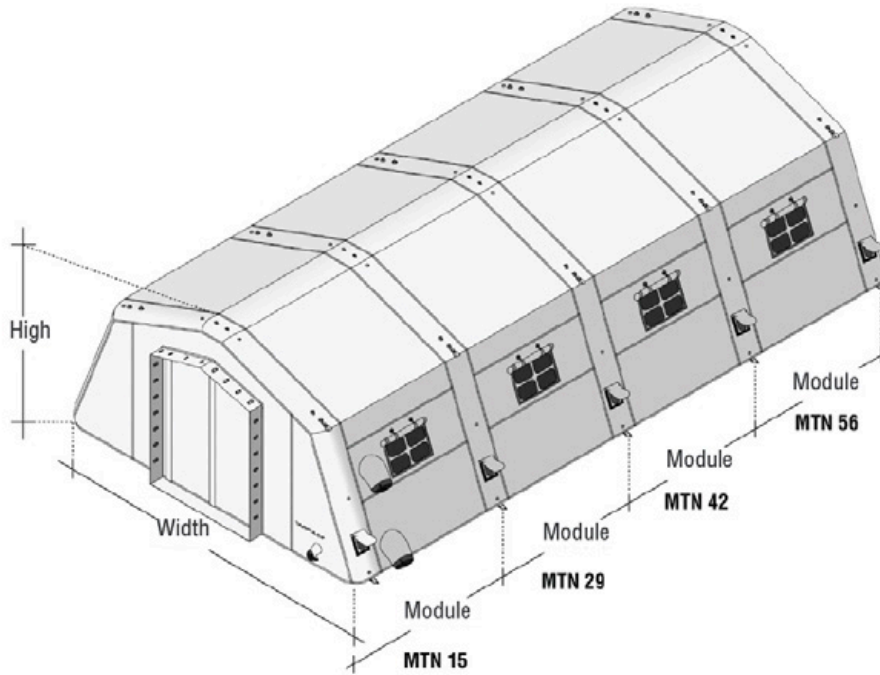

TOTAL OF DOORS AND WINDOWS FOR EACH MODEL

SIZE (M2)	Nº MODULES	DOOR	WINDOWS
15	1	2	2
29	2	2	4
42	3	2	6
56	4	2	8

AVAILABLE COLORS

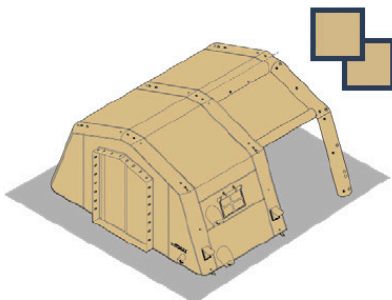

EXTERIOR PAMPA
INSIDE PAMPA

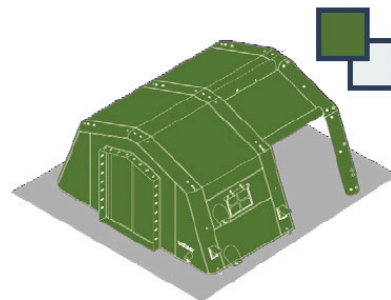

EXTERIOR OLIVE GREEN
INSIDE WHITE

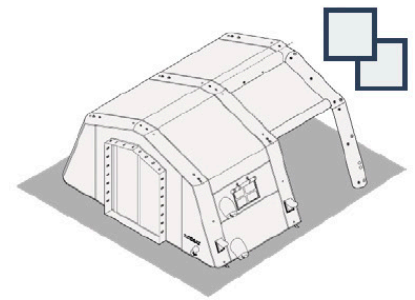

EXTERIOR WHITE
INSIDE WHITE

DECONTAMINATION SHELTERS

Now more than at any point in the world's history, viruses are disrupting life—and taking life. Your personnel are deployed to areas where disaster has taken hold, including health disasters. Get ready-made decontamination tents up in minutes so you can keep serving.

DECONTAMINATION TENTS

Super bugs and deadly viruses are becoming more and more common every year. You can protect your personnel with decontamination tents that keep infected individuals secure and their entire unit separated from contagion. Configure them to whatever your needs may be, and have them shipped anywhere in the world.

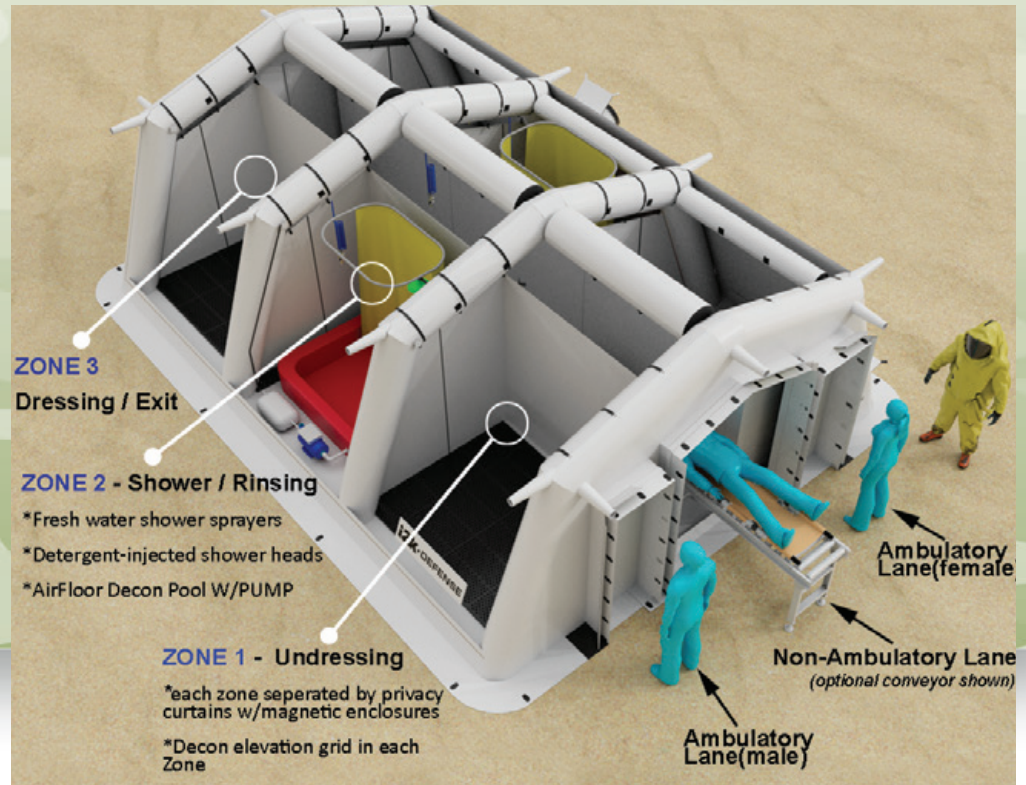

DECONTAMINATION SHELTERS (AMBULATORY & NON-AMBULATORY LANES)



RAPID RESPONSE INFLATABLE SHELTERS

i2k's inflatable emergency and recreational shelters are much easier to transport, set up, operate and strike. i2k's shelters set up fast and inflate in a matter of minutes, which will greatly improve the rapid response time in the occurrence of a disaster or deployment. Their modular design also allows them to be connected to vehicles for the operation of internal equipment or, they can be easily expanded with other shelters.



Inflatable Shelters are used by the US military, emergency, fire, law enforcement, FEMA, and Homeland Security for the use of: Rapid Response Shelters, Disaster Relief Shelters, Mobile Field Hospitals, Portable Housing, Tactical Offices, Portable Barracks, Decontamination Shelters (ambulatory and non-ambulatory), Hazmat Shelters, Hazardous/Chemical Storage, Operation/Command Centers, Bunkers & Aircraft Hangars.

All Inflatable Shelters are available with the following features:

- Sealed-Air / Air-Tight Inflatable frame with vinyl cover
- Compact, light-weight, self-contained for rapid set-up and inflation
- Fire (FR) and water resistant
- Capable of withstanding all weather conditions, including intense heat or arctic conditions
- Mesh sky lights with roll-up vinyl flaps to allow for light and ventilation and Electric Lighting.
- Easily set up by 2-3 people and can be erected in any weather on any terrain
- Units can be linked together to form a larger structure
- Removable roll-up, divided curtains
- Roll-up doors with zipper closure on front and back



ACCESSORIES



LIGHTING



SMALL GENERATORS



POWER DISTRIBUTION



SOLAR BATTERIES



FRESH & GRAY WATER BLADDERS



**NON-AMBULATORY CONVEYOR
W/ SPINE BOARD**



FLEXIBLE WASTEWATER TANKS
(568L - 6800L) 150 gal - 1,800 gal capacity. Fully collapsible flexible waste water tank accepts a standard garden hose or fire hose to fill. The water bladder is designed to be easily deployed for use with portable showers in decontamination applications.



DECON ELEVATION GRID

Prevent patients and responders from standing in contaminated water during decontamination. HazMat Elevation Grid Assemblies made from sturdy, high-density polyethylene.

GRID TYPE: SINGLE LAYER 3' X 2' X 2.8"

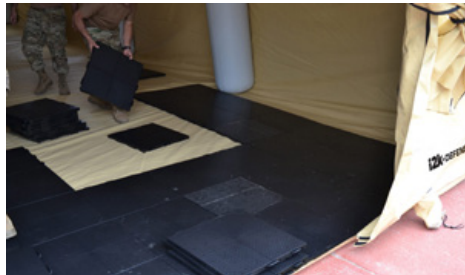

MODULAR FLOORING

- Modular floor with high impact resistance.
- Anti-Slip Surface.
- Can be placed on grass, dirt, sand etc...
- Resists heavy equipment during installation.
- Easy to transport and install
- Weight for each plaque: 4.85lbs (2.2kg)
- Storage of 52 m2 per pallet.
- Color: White.
- 100% recyclable.
- Maintenance free



**MULTI-FUEL
INSTANT
WATER HEATER
(I2K425DWH)**



**MULTI-FUEL
INSTANT
WATER HEATER
(I2K186DWH)**



WATER PUMP
Pump water quickly from collection pools to water bladders

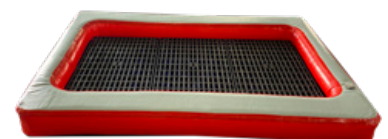

AIRFLOOR™ DECON POOL

INFLATABLE TACTICAL TRAINING WALLS

Configure tactical training spaces anywhere, anytime, with Inflatable Shoot House Training Wall Systems. Customized modular floor plans give you the flexibility to create the environment your personnel are most likely to encounter.

STANDS UP TO YOUR TRAINING DEMANDS

Training can take many forms, shapes and sizes. You need a modular solution to create your training environment, whether it's meant to simulate an urban combat zone, interior building, or anything else your needs demand. Regardless of its application, you need something that can change at a moment's notice to give your team a fresh perspective. i2K's inflatable tactical training walls set-up fast with minimal manpower, store away quickly, and are made tough to withstand use in any weather or terrain.

SEALED-AIR INFLATABLE SHOOT HOUSE TRAINING WALL SYSTEM

Inflatable Shoot House Training Wall Systems simulate force-on-force reality-based training for military and police departments, greatly improves performance and enhances survivability. Our systems can also be used with "Simunitions," a non-lethal training ammunition, in a rapidly deployable and fully scalable system that can be used to create an immersive and realistic close quarters battle training environment.

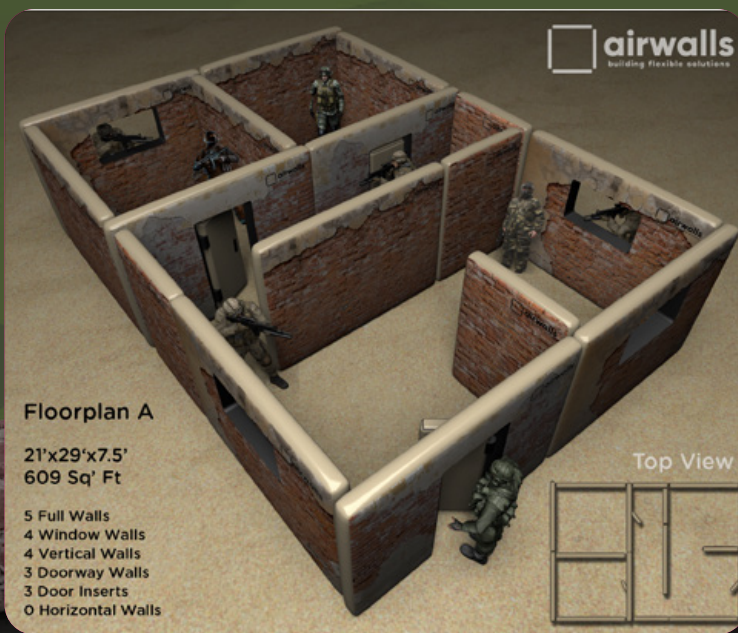

INFLATABLE TACTICAL TRAINING WALLS

- Tear, abrasion and UV-resistant, as well as waterproof and capable of withstanding extreme hot and low temperatures
- Strong and firm enough to withstand a 300lb/136kg trooper with full gear
- Heavy-duty air bladder with 18oz digitally printed exterior vinyl shell ensures Simunitions will not puncture walls
- Stainless steel D-rings to connect walls together at multiple locations on both sides
- Zinc carabiner quick links walls together
- Hook & loop (Velcro) flaps secure walls together - opposing forces can't see through cracks
- Top hook & loop (Velcro) helps roof keep interior completely dark (night-vision capable)
- Compatible with the BTI breach doors
- Resistant to L83A1 smoke grenades, hot weapons barrels, L111 training grenades and flash bang/stun grenades
- Heavy-duty transport bags, deluxe repair kits, 110v, 220v or petrol-powered inflators
- HR inflation valves and PRVs (pressure Relief Valves) expel air to enhance auto-deflation.

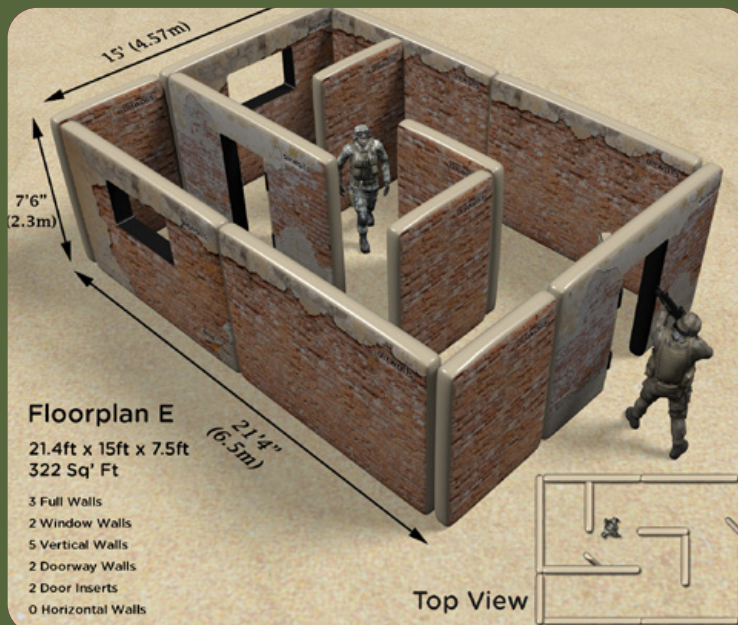
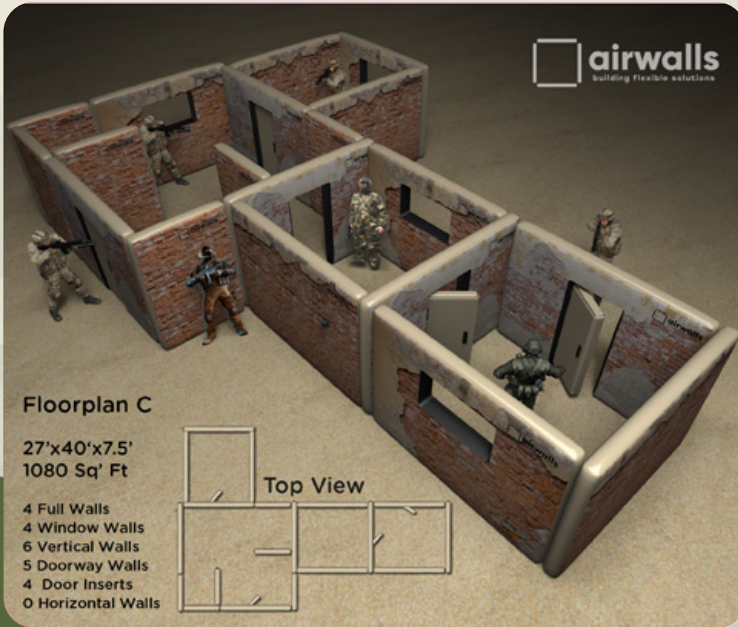

INFLATABLE SEALED-AIR MAINTENANCE AND AIRCRAFT HANGARS

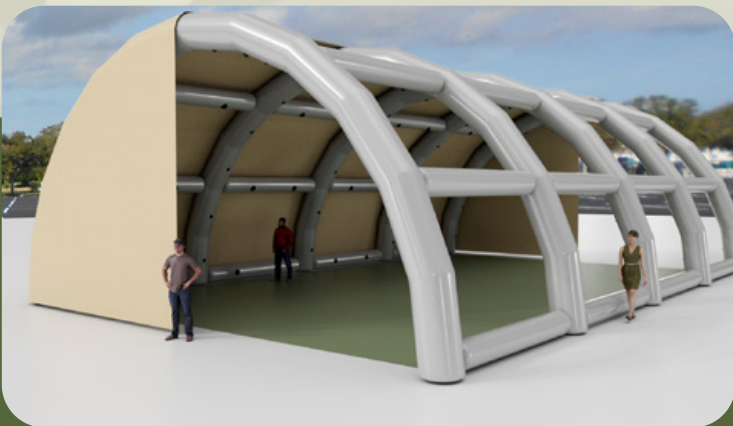

- IR BLOCKING
- RADAR REFLECTIVE MATERIALS AVAILABLE
- MANY SIZES AND VARIATIONS AVAILABLE

 **airwalls**
building flexible solutions



i2k
DEFENSE 

KILLER TOMATOES™ TARGET BALLOONS

Designed to be easy to unpack, inflate, deploy, and recover. Killer Tomatoes™ Target balloons feature the patented drogue chute that automatically self-deploys on launch. Once the drogue chute is filled, the weight of the water hold the target upright and reduces the influence of wind, helping the target holds station.

PERFECT FOR TRAINING

The patented design includes an internally mounted radar reflector in the “Catch Rain Position” as high as possible inside the target balloon. This results is a stronger radar image that was not possible with early target balloon designs. Radar visible at 16KM (10 miles) in calm sea conditions is typical.

- Internal Radar Reflector
- 6 Reinforced Metal D-Rings
- 25' Floating recovery/trip line to aid recovery
- Easy to deploy
- Towable

Sizes Available

6' x 6' x 6' (1.83m³)

14' x 14' x 14' (4.3m³)

17' x 17' x 17' (5.2m³)

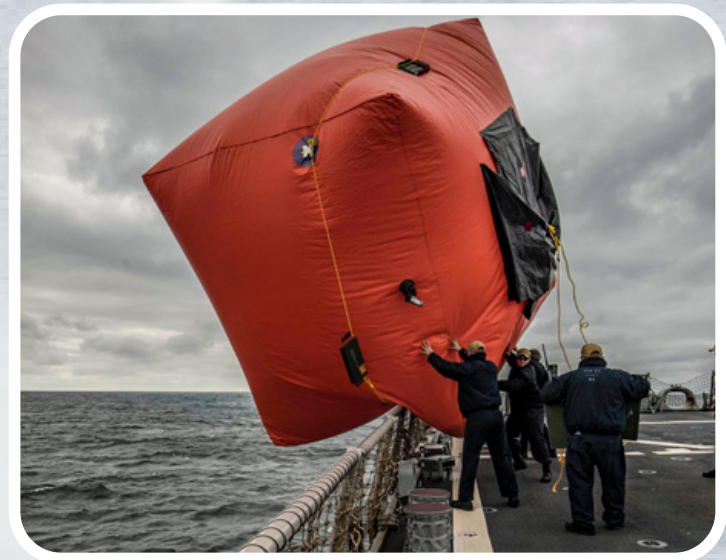
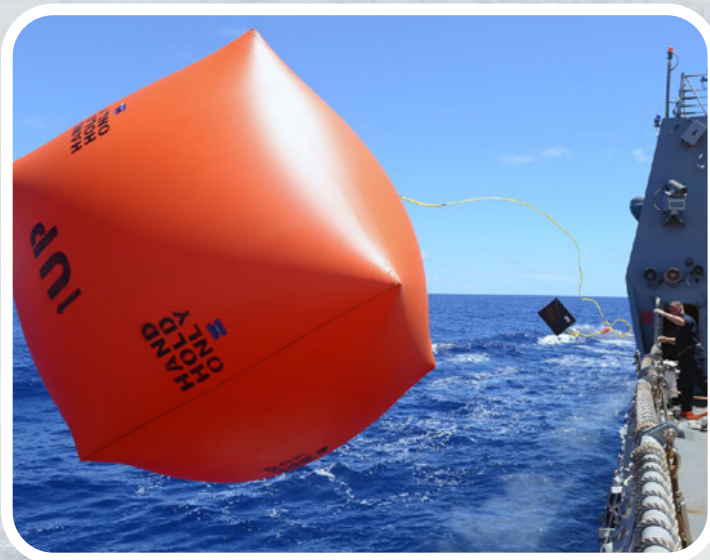

i2k AIRPAD FALL PROTECTION

NOWHERE TO TIE OFF?

AirPads™ are designed to protect workers from falls in the workplace where tying off is not available, nor practical or when redundancy is required. Common applications include aircraft manufacturing and maintenance or any other job that requires workers to perform work at dangerous heights.

Our i2k AirPads™ contain a full array of patented ZeroShock™ crumple tubes that safely and gently absorb falling bodies. With no sweet spot, the entire surface is safe to land on, even near the edges - giving workers the largest possible landing surface with the smallest footprint. Drone Landing Pads also available.

QUICK • PORTABLE • INFLATABLE FALL PROTECTION

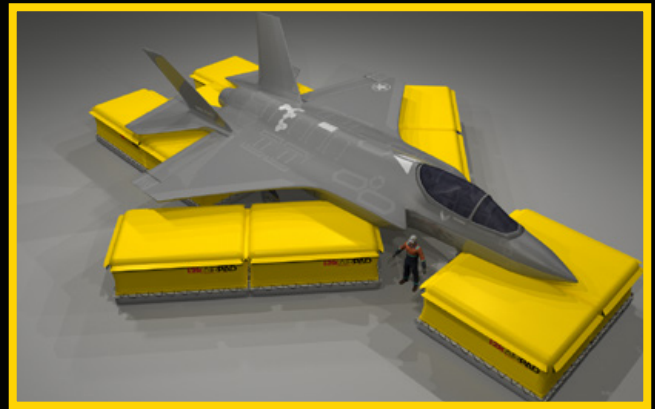

THE i2k DEFENSE PROCESS

Each of our military decoys and targets have been graded as 97% realistic-looking from the air.

We create all of our custom-made, inflatable military decoys and targets using state-of-the-art, computer-aided design software to ensure maximum accuracy and finish each inflatable product with a vinyl-coated polyester skin for ultimate verisimilitude. For creating a heat signature around elements such as a decoy's engine compartment, tank tracks or their hot spots, i2k Defense offers an Environ 110-volt flexible heating blanket that emits heat through the inflatable's vinyl skin and radiates that heat through the membrane of the material.



To identify inflatable military targets on radar, we offer Plastimo tube-type radar reflectors that reflect radar energy from aircraft. Lastly, in many instances depending on your desired level of realism, we also offer a variety of ancillary augmentations such as imitation machine guns and other three-dimensional printed plastic components to complete the overall custom look of your inflatable decoy or target.



HIGH-TECH DESIGN

All of our products are custom-patterned from three-dimensional model designs. We utilize over 15 colors of vinyl, including green, tan and black, to produce our inflatables and have the design capabilities to digitally print any variant of camouflage from a country's military or custom, textured artwork from scratch to replicate steel, rust, dirt, mud, rubber and more.



INFLATION ASSISTANCE

We offer a portable generator with inflation blower(s) for your convenience. Options include the Champion 100155 7,000/9,000-watt dual-fuel generator, the HondaFP5008 5.5-horsepower petrol blower and the Kodiak KP-1 115-volt blower.



MANUFACTURER WARRANTY

All of our inflatable decoys and targets come with a two-year manufacturer's warranty.



CONTACT US

For sales inquiries, quote requests, or custom orders, please call us at +1 (626) 788-0247, +1 626.926.5127 or email info@i2kDefense.com or visit www.i2kDefense.com

ABOUT i2K DEFENSE

i2k Defense is a privately held corporation headquartered in Los Angeles County, CA. We have proudly manufactured inflatable products for the Military, Fortune 500 companies and safety engineers since 1993.

Our professional, highly trained designers, engineers and machine operators work out of our 30,000+ square-foot manufacturing facility, overseeing production from initial concept design to final completion. With our capabilities and experience, we can design, pattern, texture, cut and sew realistic, full-sized, custom inflatables, often within a matter of weeks.

Our experienced team is widely recognized within the inflatables industry as goal-oriented leaders, dedicated to providing total client satisfaction with the resources and quality mindset necessary for producing high-performing, reliable inflatables at the best value.



**Ready to Customize
Your Military Inflatable?**

i2k Defense - 748 N. McKeever Ave., Azusa, CA, 91702, U.S.A.

i2kDEFENSE.com | 1.888.463.5848 | +1 626.926.5127 | info@i2kdefense.com

Trusted by the United States Armed Forces and the Department of Defense

